

**GREE DUCTFREE MINI-SPLITS** OUTDOOR CONDENSING UNITS  
**ROOF STAND CONFIGURATION AND ANCHOR SELECTION - WIND LOAD EXAMINATION**

CODE: FMC and FBC 7th Ed. (2020) BLDG, ASCE 7-16  
 MIAMI-DADE WIND SPEED = 195 MPH (Risk Cat. IV)

**ENGINEERING CONFORMANCE ANALYSIS:**

THE TABLE SHOWS ROOF STAND AND ANCHOR TYPES FOR VARIOUS MODELS OF HVAC OUTDOOR EQUIPMENT UP TO 3 TONS THAT MEET THE FOLLOWING ANALYSIS: • OVERTURN • SLIDING • ANCHOR PULLOUT AND SHEAR STRENGTH • EQUIPMENT INTEGRITY.

**TABLE A-2**

Model No.	Weight (lbs)	Length C (in.)	Width B (in.)	Height A (in.)	Mount E (in.)	Mount F (in.)
<b>4LIV09HP115V1AO</b>	60	26.6	11.2	21.9	12.2	17.9
<b>4LIV12HP115V1AO</b>	60	26.6	11.2	21.9	12.2	17.9
<b>4LIV09HP230V1AO</b>	56	26.6	11.2	21.9	12.2	17.9
<b>4LIV12HP230V1AO</b>	57	26.6	11.2	21.9	12.2	17.9
<b>4LIV18HP230V1AO</b>	72	29.3	11.8	21.9	13.1	20.2
<b>4LIV24HP230V1AO</b>	97	35.0	13.4	26.0	14.6	22.4
<b>4LIV30HP230V1AO</b>	113	36.3	14.5	29.4	15.6	24.0
<b>4LIV36HP230V1AO</b>	127	36.3	14.5	29.4	15.6	24.0

Installation Requirements								
Roof Stand	Support Angle	Strapping		Design Check: Nomnal / Req'd				
Conc Anchor Type	Number of Leg Frames	Support Angle	Unit foot to Support Anchor	# of Straps if Required	Gauge thickness	Conc Anc Pullout	Conc Anc Shear	Unit Foot Anchor Pullout
A-1	2	1/4	A-4	Yes, 2	22ga	1.39	2.18	4.19
A-1	2	1/4	A-4	Yes, 2	22ga	1.39	2.18	4.19
A-1	2	1/4	A-4	Yes, 2	22ga	1.39	2.18	4.18
A-1	2	1/4	A-4	Yes, 2	22ga	1.39	2.18	4.19
A-1	2	1/4	A-4	Yes, 2	22ga	1.25	1.97	4.00
A-2	2	1/4	A-4	Yes, 2	22ga	1.18	2.55	2.70
A-3	2	1/4	A-4	Yes, 2	20ga	1.45	3.91	2.20
A-3	2	1/4	A-4	Yes, 2	20ga	1.45	3.91	2.21

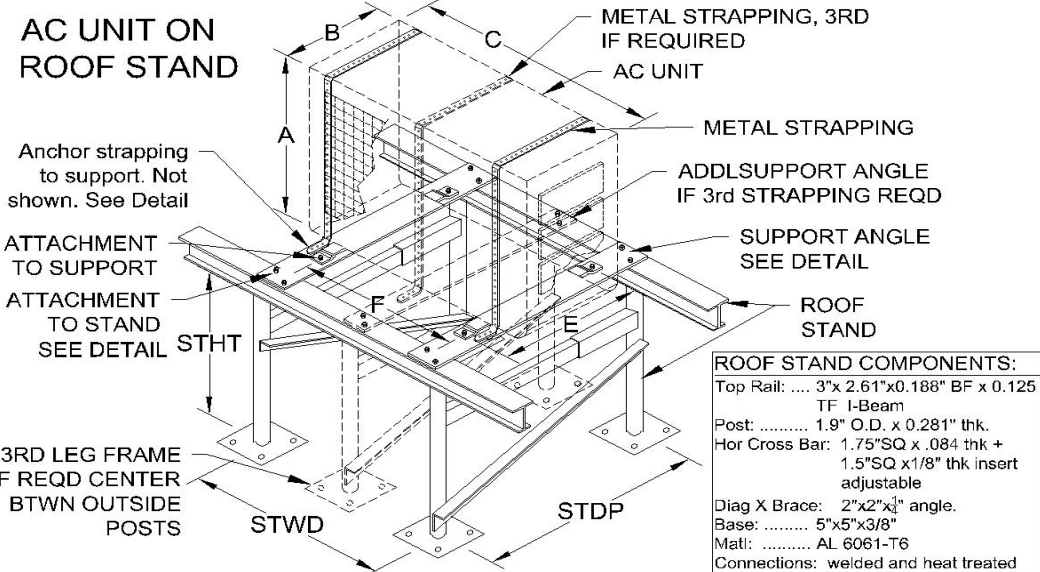

Bri-Ko Engineering, Inc., Structural Analysis  
 Spreadsheet designed by: B. Schwartz, PE  
 Date data input: 2-Mar-23

Calc Sht: EC-1 Mechanical Equipment on Roof Stand Calc  
 Description: Structural Analysis of roof stand mounted mechanical equipment to resist wind forces.  
 Code: FBC 7th Ed. (2020) and ASCE 7-16.

**Design Methodology and Load Combinations:**  
 Design Method: LRFD  $\Phi = 0.90$   
 Load Combos: FBC Eqn. 16-6 0.9 D + 1.0 W  
 Wind Forces: based on ASCE 7-16 Eqn. 29.4-1, and FBC 1620.6

Ultimate Design Wind Speed, Vult (3-sec gust): **195 mph** Miami Dade  
 Nominal Design Wind Speed, Vasd: **151 mph**  
 Risk Category: **IV** Dir., Topo., Gust Effect: **0.90** 1.00 N/A  
 Height, h: **60 ft** Exp. Cat.: **C** Vel. Pres. Exp Coef., Kz: **1.137**  
 Enclosure Cat: **N/A**  
 Velocity Pressure  $q_h = 0.00256 K_z K_{zt} K_d V^2$  (lb/ft<sup>2</sup>)  $q_h = 99.6$  psf  
 F =  $q_h(GC_r)A_r$  (GC<sub>r</sub>)<sub>v,l</sub> = (1.5 ver., 1.9 lat.) F<sub>ver, Flat</sub>: **149.4 psf, 189.2 psf**

**Limit States:** for illustration purposes only:  
 Select UnitType: **4LIV** Select Model # **4LIV36HP230V1AO**  
 Number of Leg Frames is 2

**Loads, (lbs):** P1= 1402 P2= 548 P3= 561 PD= 127

**Resistance to sliding stand post:**  
 Req'd. Shear/leg = **378 lbs** Nominal Shear per leg: **850 lbs** CHECKS OK

**Resistance to sliding anchors to support:**  
 Req'd Sher/anc: **378 lbs** Nom Shear per bolt: **900 lbs** CHECKS OK

**Resistance to Moment and Uplift:** Use Load Combo: **0.90 D + 1.00 W**  
 Overturn M at stand base: **79.0 k-in** Base Pullup: **705 lbs**  
 Overturn M at unit foot: **24.0 k-in** Foot Pullup: **799 lbs**  
 Nom Pullup Str, 4xConcAnc, Bolt: **5480 lbs** **1700 lbs** CHECKS OK

**Verification of Support Angle:**  
 Forces, lbs: -R<sub>1</sub> = 423 R<sub>2</sub> = 799 R<sub>3</sub> = 525 R<sub>4</sub> = 149  
 Required Mom.: **4.3 k-in** Req'd Section Modulus: **0.229 in<sup>3</sup>**  
 Use: 3"x3"x1/4" with Sx= 0.547 in<sup>3</sup>

**Unit Integrity:** If Required. Only if manufacturer does not state design wind pressure.  
 Required tension on strap= **817 lbs**  
 Strap width, gauge= **1.375 in.** **20ga** min gauge thickness  
 Steel Strength= **45 ksi min.** Strength of strap= **981 lbs** CHECKS OK

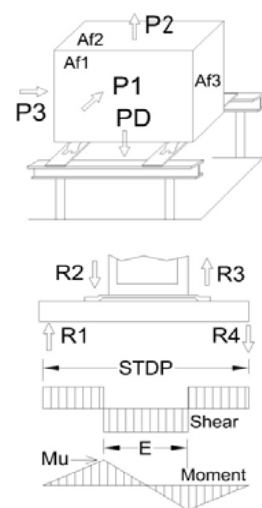

Roof Stand min, maxs:	Leg Max Forces(lbs)			
limits	STWD	STDP	STHT	Tension: 5860
min:	24 in.	28 in.	18 in.	Comp.: 6000
max:	36 in.	36 in.	33 in.	Shear: 1700

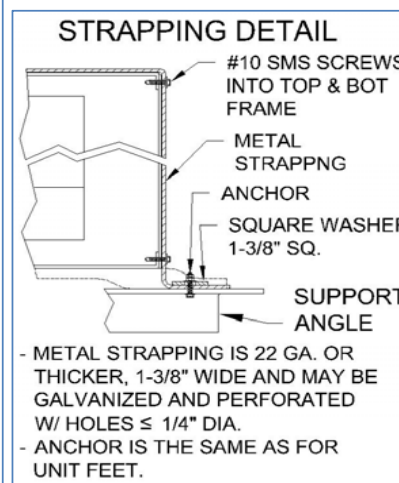
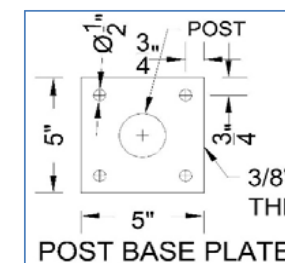
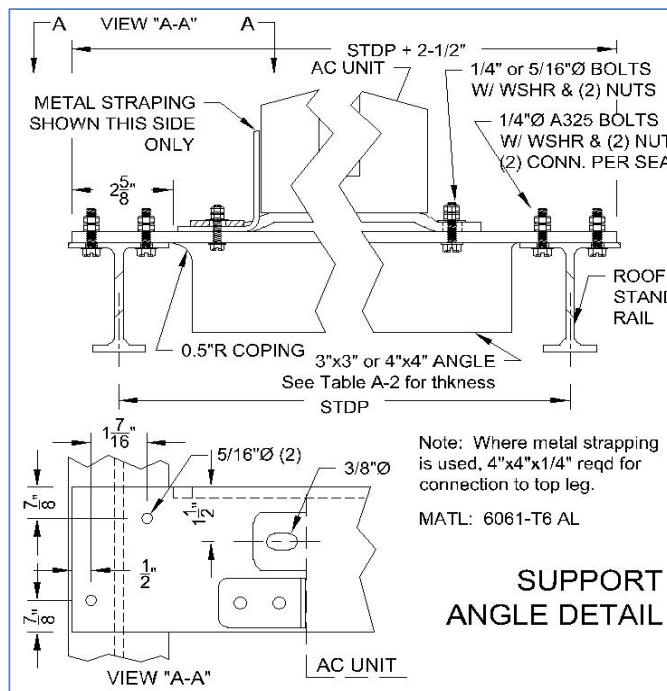

- Anchor Type is the minimum, higher strength types permitted.

**GENERAL NOTES:**

- THIS ENGINEERING REPORT DOCUMENTS THE ANALYSIS OF AC EQUIPMENT MOUNTED ON A ROOF STAND AND THE ASSOCIATED ANCHORING SYSTEMS TO RESIST DEAD WEIGHT AND WIND LOAD FORCES.
- THE LOAD PATH VERIFIED IS FROM THE EQUIPMENT AS A SINGLE UNIT, ENCLOSURE FASTENERS, UNIT LEG ANCHORS, ROOF STAND CROSS SUPPORT TO ROOF STAND TO CONCRETE SLAB.
- THE AC UNIT IS MOUNTED ON A METAL ROOF STAND WHICH IS SECURED TO A ROOF CONCRETE SLAB.
- ANCHORS USED TO FASTEN THE UNIT TO THE ROOF STAND ARE A307 OR HIGHER STRENGTH STEEL BOLTS.
- THE ROOF STAND IS SUPPLIED BY THE MANUFACTURER INDICATED IN THIS DOCUMENT AND IS INSTALLED IN CONFORMANCE WITH THE ENGINEERING DOCUMENT REFERENCED.
- UNIT INTEGRITY, IF NOT DESIGNATED BY THE MANUFACTURER FOR THE STATED WIND PRESSURES, IS ADDRESSED BY STRAPPING ATTACHED TO THE UNIT AND ANCHORED TO THE SUPPORT ANGLES. THIS RESISTS SHELL AND FRAME SEPARATION.

**CALCULATIONS:**

- THE WIND LOAD ACTING NORMAL TO THE LARGE VERTICAL SIDE OF THE AC UNIT IS USED FOR WORST CASE SHEAR.
- THE WIND LOAD ACTING ON THE TOP OF THE UNIT UPWARD AND THE HORIZONTAL WIND LOAD IS USED TO CALCULATE UPLIFT AND MOMENT.
- THESE FORCES MUST BE RESISTED BY THE SHEAR AND TENSILE STRENGTH OF THE ANCHORS BOTH HOLDING THE UNIT TO THE SUPPORT BAR AND THE SUPPORT BAR TO THE ROOF STAND.
- THE MOMENT AND SHEAR MUST BE TRANSFERRED FROM THE AC UNIT TO THE ROOF STAND BY A SUPPORT BAR AS THE AC UNIT DEPTH IS LESS THAN THE ROOF STAND DEPTH.
- MAX MOMENT AND SHEAR TO THE SUPPORT BAR DETERMINE SELECTION OF THE SUPPORT BAR.

**ROOF STAND NOTES:**

- ROOF STAND IS BASED ON A DESIGN BY R.M. ENTERPRISES, PER ENGINEERING DRWG DATED 03-09-2012 SIGNED AND SEALED BY P.E.#56902, BUT VERIFIED BY BRI-KO ENGINEERING
- STHT = STAND HEIGHT WITH MIN 18", MAX 33".
- STWD = STAND WIDTH = 24" MIN, 36" MAX.
- STDP = STAND DEPTH = 28" MIN, 36" MAX.
- SUPPORT ANGLE AND FASTENERS OF SUPPORT TO STAND AND SUPPORT TO AC UNIT ARE DEFINED IN DETAIL BELOW.
- AC UNIT MUST BE CENTERED ON SUPPORT.W. ROOF STAND LIMITS.) MAX COMPRESSION PER FOOT = 6000 LBS. MAX UPLIFT PER FOOT = 5860 LBS. MAX SHEAR PER TWO FEET = 1700 LBS.

TABLE A-1 ANCHOR TYPE AND ALLOWABLE STRENGTHS				
SYM	ANCHOR DESCRIPTION & MANUFACTURER	EMBED	STRENGTH AT MIN SPACING	
			PULL OUT (LBS)	SHEAR (LBS)
A-1	1/4" TAPCON (Buildex)	1-3/4"	505	415
A-2	5/16" Hvy Duty Tapcon (Buildex)	1-3/4"	695	760
A-3	3/8" WEDGE BOLT (Powers)	2-1/2"	1025	1370
A-4	1/4" A307 Bolt	N/A	1700	900
A-5	5/16" A307 Bolt	N/A	2500	1500

Note: Anchors A-1, A-2, A-3 are into 3000 psi min concrete, 4" thick min.

Sheet: **ENG-1** BRI-KO ENGINEERING INC Cert. Of Auth.:#27622 tel: 954.648.6218  
 Doc: **Page 1 of 1**  
 Gree -4LIV Roof Stand  
 Issue Date: **2-Mar-23**  
 Dwn By: **B.S.**  
 Dwg Size: **11x 17**

This item has been digitally signed and sealed by Brian I Schwartz on the date adjacent to the seal. Printed copies of this document are not considered signed and sealed and the signature must be verified on any electronic copies.